

Errata

Title & Document Type: 1120A 500 MHz Probe Operating Note

Manual Part Number: 01120-90903

Revision Date: February 1983

About this Manual

We've added this manual to the Agilent website in an effort to help you support your product. This manual provides the best information we could find. It may be incomplete or contain dated information, and the scan quality may not be ideal. If we find a better copy in the future, we will add it to the Agilent website.

HP References in this Manual

This manual may contain references to HP or Hewlett-Packard. Please note that Hewlett-Packard's former test and measurement, life sciences, and chemical analysis businesses are now part of Agilent Technologies. The HP XXXX referred to in this document is now the Agilent XXXX. For example, model number HP8648A is now model number Agilent 8648A. We have made no changes to this manual copy.

Support for Your Product

Agilent no longer sells or supports this product. You will find any other available product information on the Agilent Test & Measurement website:

www.agilent.com

Search for the model number of this product, and the resulting product page will guide you to any available information. Our service centers may be able to perform calibration if no repair parts are needed, but no other support from Agilent is available.



Agilent Technologies



**HEWLETT
PACKARD**

500 MHz PROBE

Model
1120A

SERIALS PREFIXED: 1336A

OPERATING NOTE/FEBRUARY 1983

1. DESCRIPTION.

2. The Hewlett-Packard Model 1120A 500 MHz Probe (figure 1) is a 1:1 active voltage probe which provides low input capacitance, high input impedance, high current gain and wide bandwidth. The probe has a probe-tip impedance of 100 kilohms shunted by less than 3 picofarads capacitance and also features very low drift and noise. When used with the voltage-divider tips (accessories), the input shunt capacitance is less than 1 picofarad.

3. The Model 1120A permits the operator to test high-frequency circuits without significant loading effects. High input impedance is maintained by a field-effect transistor (FET) circuit.

4. Power for the probe is provided by HP oscilloscopes with probe power or with a probe power option, HP oscilloscope plug-in units with probe power, or Model 1816A remote sampler. When operated with instruments having no probe power, the

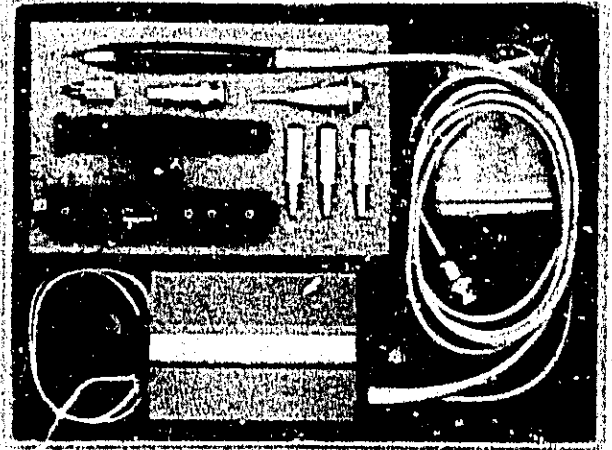

1120A-001-04-75

Figure 1. Model 1120A 500 MHz Probe

Table 1. Specifications

ELECTRICAL CHARACTERISTICS	
BANDWIDTH	
Dc-coupled: dc to >500 MHz.	
Ac-coupled: <1.5 kHz to >500 MHz.	
PULSE RESPONSE	
Rise time: <0.75 ns.	
Perturbation: <±10% measured with 1 GHz sampler.	
GAIN	
Active probe: 1:1, ±5%.	
DYNAMIC RANGE	
±0.5 V with ±5 V offset (dc).	
NOISE	
Approximately 2.5 mV (measured tangentially) with 1 GHz sampler.	
DRIFT	
Probe tip: <±100 μV/°C.	
Amplifier: <±200 μV/°C.	
INPUT IMPEDANCE	
100 kilohms shunted by <3 pF at 100 MHz; with 10:1 divider shunt capacitance is <1 pF (at 100 MHz).	
MAXIMUM INPUT	
±80 V.	
GENERAL	
WEIGHT	
Net: 1.8 kg (4 lb).	
Shipping: 3.2 kg (7 lb).	
POWER	
Supplied by instruments with probe power or Model 1122A Probe Power Supply.	
LENGTH	
Over-all length (controller, probe and probe cable) approximately 4 ft.	
ACCESSORIES FURNISHED	
MODEL 10241A 10:1 DIVIDER	
Increases input impedance to approximately 1 megohm; shunt capacitance <1 pF at 100 MHz. Increases dynamic range to ±5 V, offset range to ±50 V, and maximum input voltage to ±350 V. Divider accuracy, ±6%.	
MODEL 10243A 100:1 DIVIDER	
Increases input impedance to approximately 1 megohm; shunt capacitance <1 pF at 100 MHz. Increases dynamic range to ±50 V, offset range to ±350 V, and maximum input voltage to ±350 V. Divider accuracy, ±6%.	
MODEL 10242A BANDWIDTH LIMITER	
Limits Model 1120A bandwidth to approximately 27 MHz shunted by 6 pF. Reduces gain <2%.	
ADDITIONAL ITEMS	
Other accessories furnished with the Model 1120A are a 2.5-inch ground lead, spare probe tips, BNC probe adapter, probe hook-tip, probe holder and mounting adapter.	

Operating Note Part Number 01120-90903
Microfiche Part Number 01120-90803



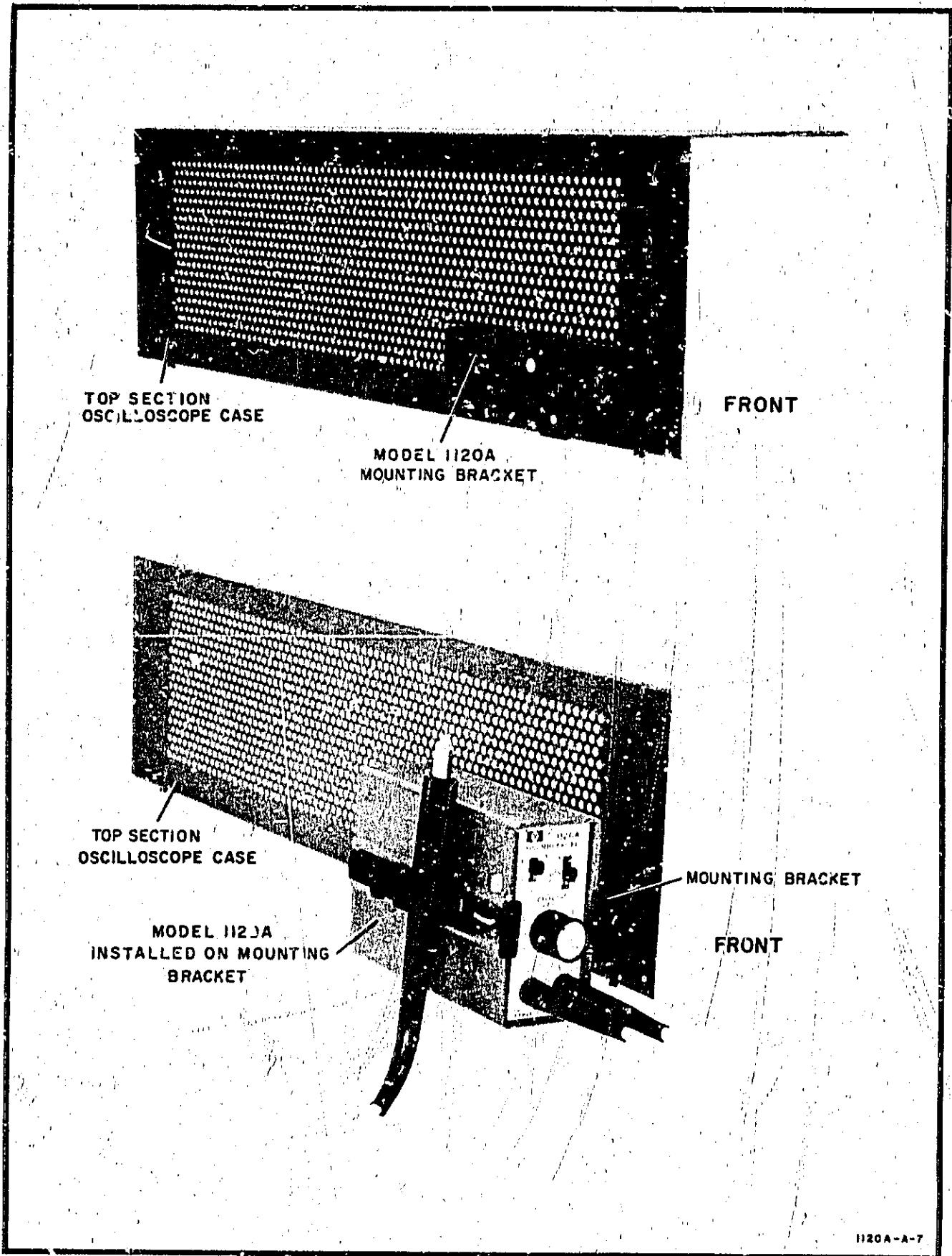

Figure 2. Mounting Bracket Installation

Model 1122A Probe Power Supply must be used as a power source. Refer to table 1 for complete specifications on the 1120A.

5. CLAIMS.

6. Upon receipt, inspect the instrument for damage and if none is noted, accomplish the performance checks. Hewlett-Packard Company guarantees the performance of the instrument as stated in the certification located near the back of this note. If the physical or operating conditions of the instrument are unsatisfactory, notify the carrier and the nearest HP Sales/Service Office immediately. HP will arrange for repair or replacement without waiting for settlement of the claim by the carrier.

7. INSTALLATION.

8. A mounting assembly is furnished with the Model 1120A which permits mounting the instrument on the

side of an oscilloscope cover. To install the mounting assembly, the upper oscilloscope cover must be removed. Align the mounting assembly stand-off bushings with any two of the perforations in the side of the oscilloscope cover and attach with the screws provided.

NOTE

The mounting assembly may be attached to either side of an oscilloscope cover. Mounting the assembly as low as possible will minimize the danger of damaging the probe tip when the probe is in the probe holder.

9. When the mounting assembly is attached to a Hewlett-Packard oscilloscope of the 180-series, the bracket should be mounted in the third row of perforated holes (from the bottom of the cover). This will provide low mounting plus access to the cover attachment slides or screws (see figure 2).

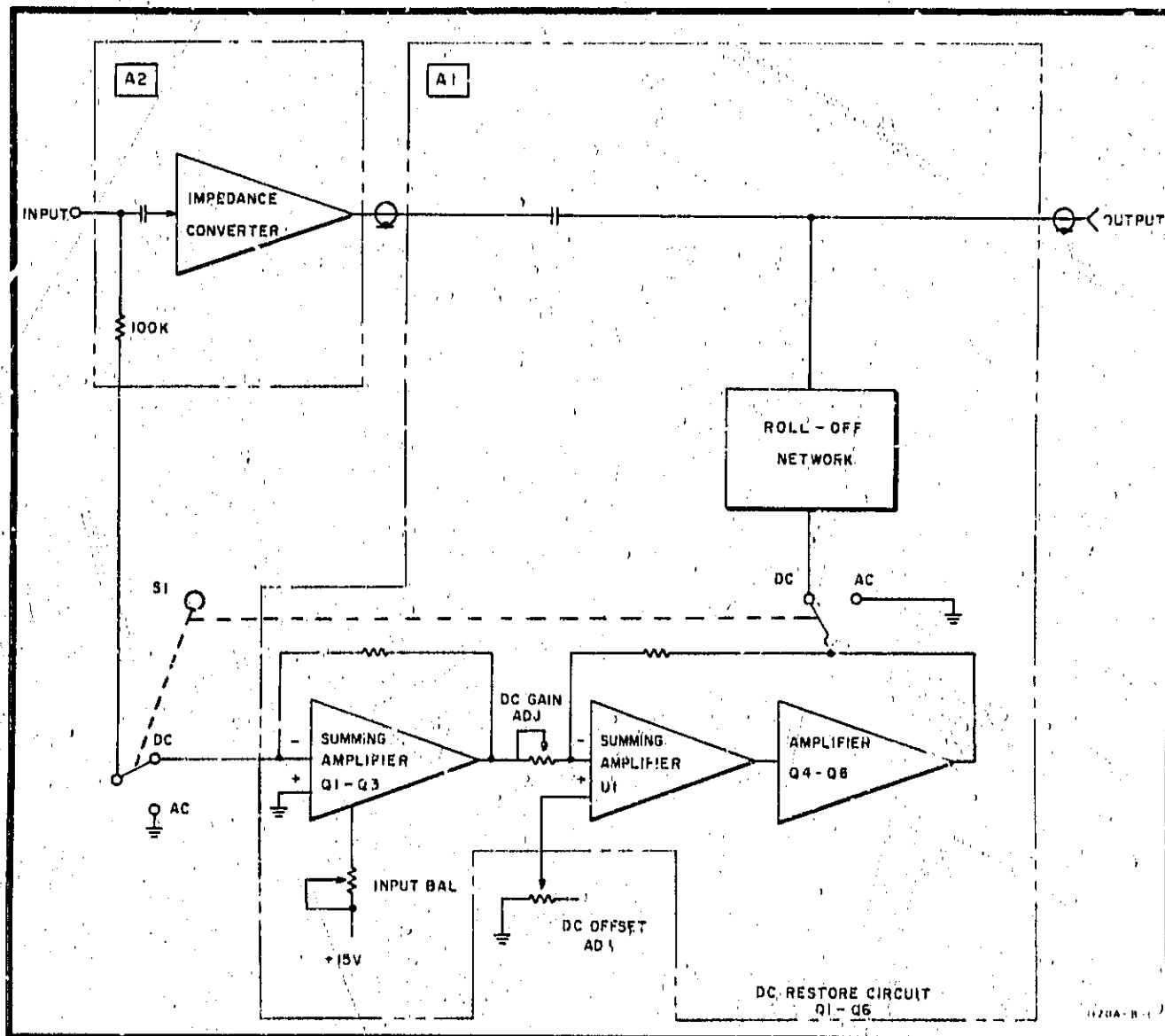

Figure 3. Model 1120A Functional Block Diagram

10. THEORY OF OPERATION.

11. BLOCK DIAGRAM.

12. Figure 3 is a functional block diagram of the Model 1120A. The input capacitor, impedance converter, and 100-kilohm resistor are located in the probe tip microcircuit. The impedance converter is a current amplifier with unity voltage gain. Output impedance of the converter matches a 56-ohm transmission line which results in a current gain of approximately 4000 at low frequencies. When the AC mode of operation is used, a transmission line connects the output of the impedance converter to the controller assembly (A1). The controller assembly capacitively couples the signal to the output cable. Unity gain is maintained when the signal is terminated in a 50-ohm load with a low-frequency roll-off at approximately 1.5 kHz. If low frequency response is not needed, the ac mode of operation can be used for signals of less than ± 100 volts (dc plus peak ac) with a ± 0.5 volt dynamic range. When the response below 1.5 kHz becomes necessary, the DC mode of operation should be used. The ac signal path remains the same. In addition, the input signal from the probe tip is applied to a summation amplifier in the DC-restore circuit (on the controller assembly). The summation amplifier produces a unity-gain output. A second summation amplifier compares the ac-coupled output signal to the output of the first summation amplifier. The output of the second summation amplifier (with its associated circuitry) will correct the low-frequency roll-off. At higher frequencies, the roll-off network decouples the DC-restore circuit from the output.

13. DETAILED THEORY.

14. The impedance converter is a thin-film resistor-conductor network to which transistor chips are attached. See figure 16 for the probe circuitry. The probe uses a field-effect transistor (FET) source follower (Q1) for the input stage. The FET provides all extremely high input impedance (similar to a vacuum tube) which reduces loading of the circuits under test. The input stage is followed by a feedback amplifier circuit (Q2-Q3) which produces a voltage gain of two. Transistor Q4 functions as an emitter follower which reduces the output impedance level to 5 ohms at low frequencies. To match the 50-ohm transmission line, a 45-ohm resistor (A2R11) is added in series with the output of Q4. This additional resistance reduces the gain of the amplifier, resulting in the overall voltage gain of unity.

15. In the DC mode of operation, the ac signal from the converter is coupled through the controller as in the AC mode of operation (see figure 19). In addition, the probe input signal is applied to the DC-restore circuit through resistor A2R2 and the AC-DC switch (S1). The input circuit consists of a current summing amplifier (Q1-Q3). If an input from the probe is $+0.5$

volt, the output of the summing amplifier (emitter of Q3) will be -0.5 volt. This output is fed back to the input of transistor Q1, maintaining the input at 0 volt (virtual ground). The output of transistor Q3 also is applied through resistor R16 and DC GAIN potentiometer R17 to the second summing amplifier (U1). Amplifier U1 is an integrated circuit and functions as an error detector. It compares the output signal from the roll-off network (L3, L4, R14 and R15) to the output of transistor Q3. When the amplitude of the output signal decreases at low frequencies (due to ac-coupling), U1 and the associated output circuitry (Q4 through Q6) develop a compensating voltage which restores the gain of the output signal to unity.

16. The dynamic range of the Model 1120A is ± 0.5 volt (without voltage dividers). When using the offset circuit, the dynamic range becomes a 1-volt window in which the input signal is observed. The offset range is from -5 volts to $+5$ volts. Figure 4 shows the 1 volt window in relation to the offset range.

17. When observing ac signals which are riding on large dc voltages and dc coupling is necessary, the offset circuit should be used. If the input signal is positive, the offset switch (S2) should be set to the (-) position. Rotate the offset vernier (R1) clockwise until the trace returns to the center of the oscilloscope CRT. If the input signal is negative, the offset switch (S2) should be set to the (+) position and the input signal centered on the oscilloscope CRT using R1. The magnitude of the input dc level will determine the number of turns required to center the trace.

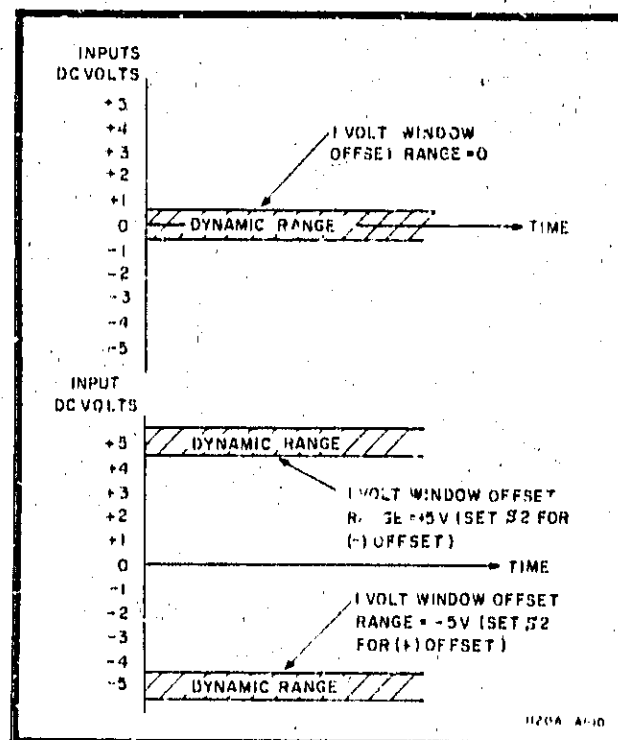

Figure 4. Offset Operating Range

18. When the dc level of the input signal is greater than ± 0.6 volt, the output of the DC-restore circuit will limit at approximately $+0.6$ volt or -0.6 volt (R1 fully counterclockwise). The dynamic range of the ac signal remains at ± 0.5 volt. See figure 5 for comparison between an input signal using the offset circuit and an input signal not using the offset circuit.

19. DIVIDER ACCESSORIES.

20. There are two divider probe tips furnished with the Model 1120A. The Model 10241A is a 10:1 divider which increases the input impedance to 1 megohm shunted by less than 1 picofarad capacitance (at 100 MHz). When using the Model 10241A, the dynamic range of the Model 1120A is increased to ± 5 volts. The offset range is increased to ± 50 volts and the maximum input voltage range is increased to ± 350 volts.

21. The Model 10243A is a 100:1 divider which increases the input impedance to 1 megohm shunted by less than 1 picofarad capacitance (at 100 MHz). When using the Model 10243A, the dynamic range of the Model 1120A is increased to ± 50 volts with a maximum input voltage range of ± 350 volts.

22. PERFORMANCE CHECK AND ADJUSTMENTS.

23. Figure 6 identifies the Model 1120A and its accessories and table 2 lists recommended test equip-

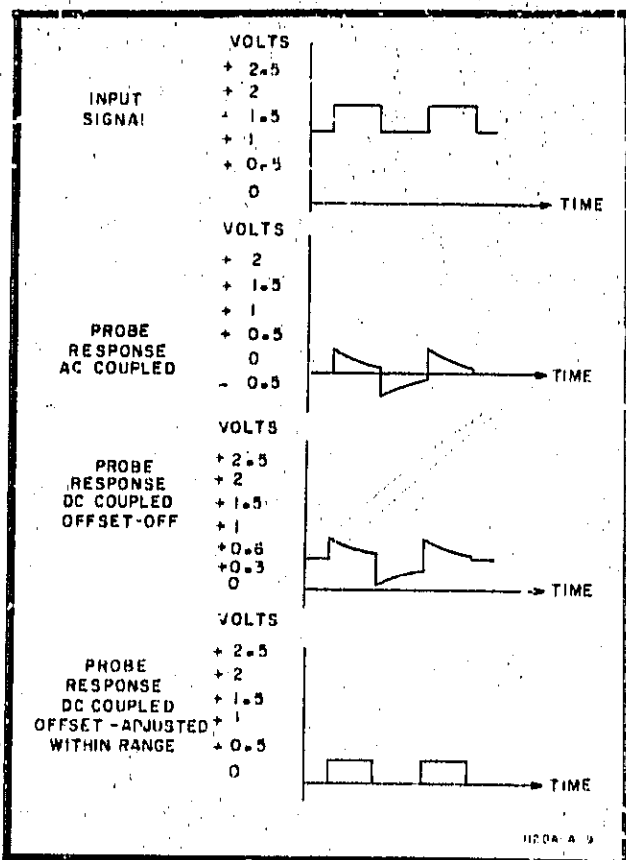

Figure 5. Low-frequency Offset Operation

ment. To accomplish the performance checks and adjustments, proceed as follows:

CAUTION

Do not apply dc voltage levels or ac voltage peaks greater than $+80$ volts. Excessive voltage will damage the probe input circuitry.

- a. Remove the Model 1120A housing to expose board assembly A1.
- b. Connect the Model 1120A as shown in figure 7 for the Input Balance check.

Table 2. Recommended Test Equipment

Recommended Instrument		Required Characteristics
Type	HP Model	
Sampler Sampling Head	1811A 1432A	4 GHz, 90 picoseconds pulse
Pulse Generator Diode Mount	1105A 1108A	60 picoseconds
RX Meter	250B	Measure <3 pF at 100 MHz
DC Null Voltmeter	419A	1 mV capability
Oscilloscope Dual Trace Amplifier Time Base Sampling Time Base	180C 1801A 1820C 1810A	
Square-wave Generator	211B	5 kHz
VHF Oscillator	3200B	500 MHz
DC Power Supply	1122A	DC power for probe
Coaxial Attenuator	8491A	20 dB Attenuator
50-ohm feed-through termination	10100C	Termination
50-ohm Tee Connector		T connection for monitoring signal

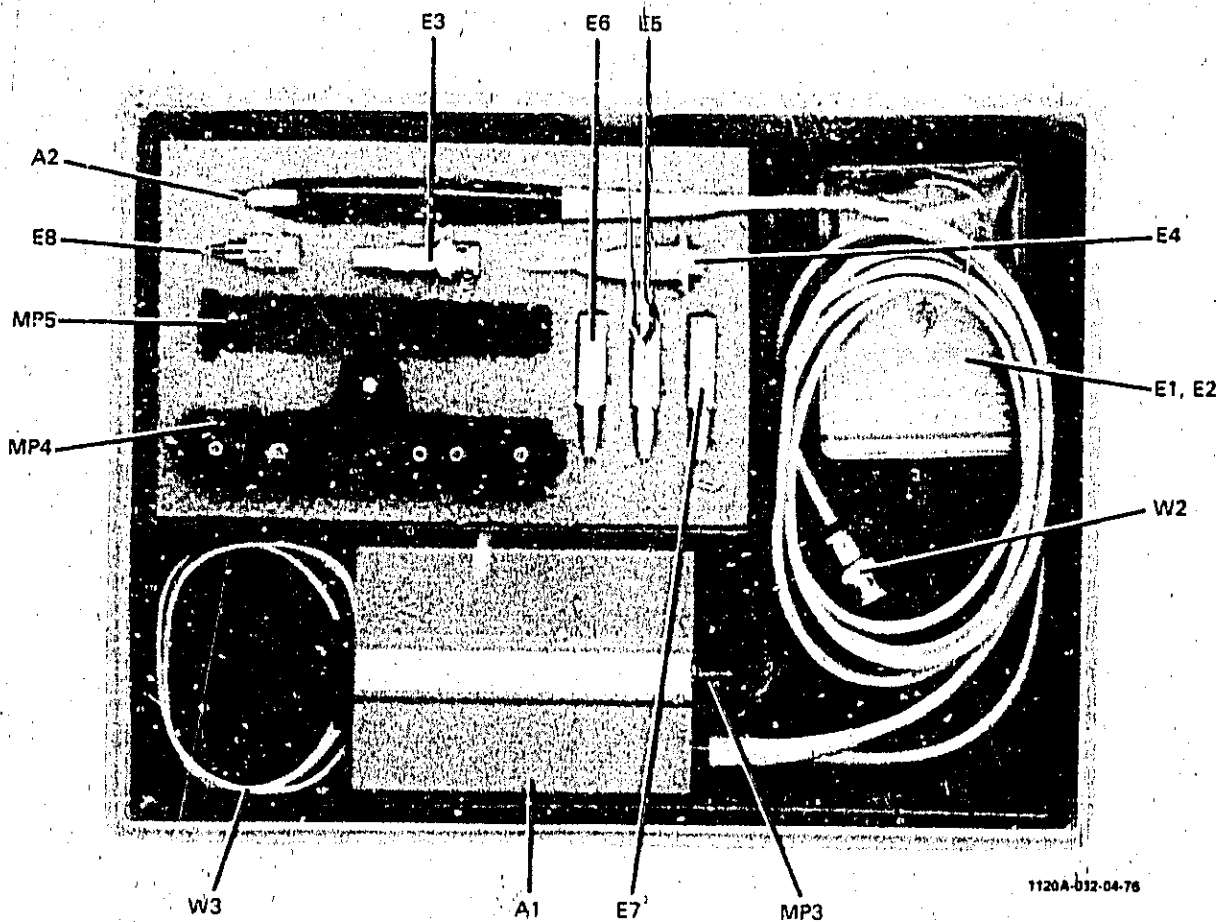

1120A-012-04-76

- | | | | |
|--------|--------------------------------------------|------|-----------------------------------|
| A1. | Model 1120A controller assembly. | E7. | 100:1 voltage divider. |
| A2. | Active probe. | E8. | Spanner coupler for active probe. |
| E1-E2. | Spare probe tips and ground lead assembly. | MP3. | Offset knob assembly. |
| E3. | BNC probe adapter. | MP4. | Model 1120A mounting bracket. |
| E4. | Hook-tip adapter. | MP5. | Probe holder. |
| E5. | 10:1 voltage divider. | W2. | Output cable assembly. |
| E6. | Bandwidth limiter. | W3. | Input dc power cable. |

Figure 6. Model 1120A and Accessories

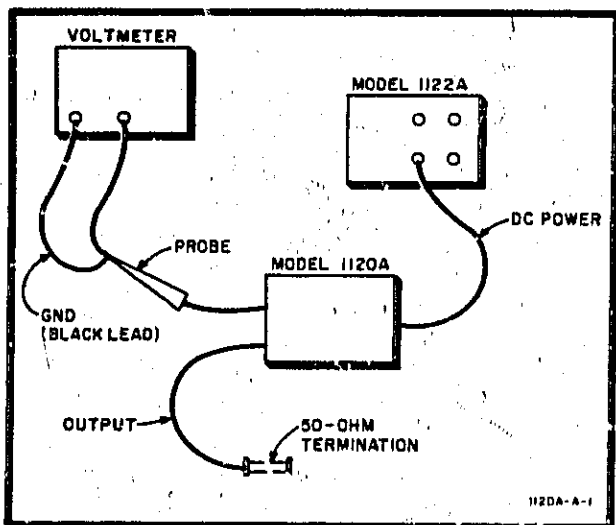

Figure 7. Input Balance Test Setup

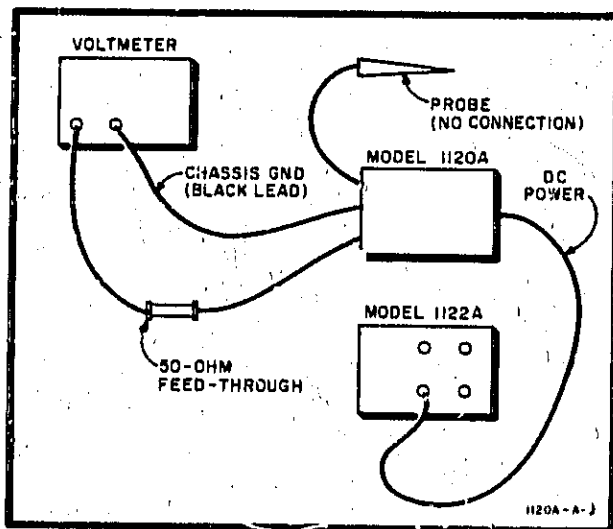

Figure 8. DC Offset Test Setup

c. Set the Model 1120A controls as follows:

AC-DC switch DC
 OFFSET switch OFF

d. Apply power to the Model 1120A.

e. Connect the positive lead of the voltmeter to the probe tip and the ground lead to the ground on the probe tip.

f. Set the voltmeter to a convenient range and proper polarity. The voltage indication should be less than ± 1.0 millivolt. If the voltage indication is greater than ± 1.0 millivolt, proceed to step g. If the voltage indication is within tolerance, proceed to paragraph 24.

g. Adjust the dc voltage to less than ± 1.0 millivolt with the INPUT BAL potentiometer (R4) on board assembly A1 (see figure 15 for adjustment locations).

24. Connect the equipment as shown in figure 8 for the DC Offset check.

a. Set the Model 1120A controls as follows:

AC-DC switch DC
 OFFSET switch OFF

b. Connect the positive lead of the voltmeter to the center conductor of the 50-ohm feed-through connector. Connect the voltmeter ground lead to the Model 1120A chassis ground.

c. Set the voltmeter on a convenient range.

d. The voltage indication should be less than ± 1.0 millivolt. If the voltage indication is greater than ± 1.0 millivolt, proceed with step e. If the voltage indication is within tolerance, proceed with paragraph 25.

e. Adjust the output voltage of the Model 1120A to less than ± 1.0 millivolt with the OFFSET potentiometer (R3) located on board assembly A1.

25. Connect the equipment as shown in figure 9 for Low-frequency Gain check.

a. Set the Model 1120A controls as follows:

AC-DC switch DC
 OFFSET switch OFF

b. Set the square-wave generator controls as follows:

Frequency 5 kHz
 Amplitude 5 volts

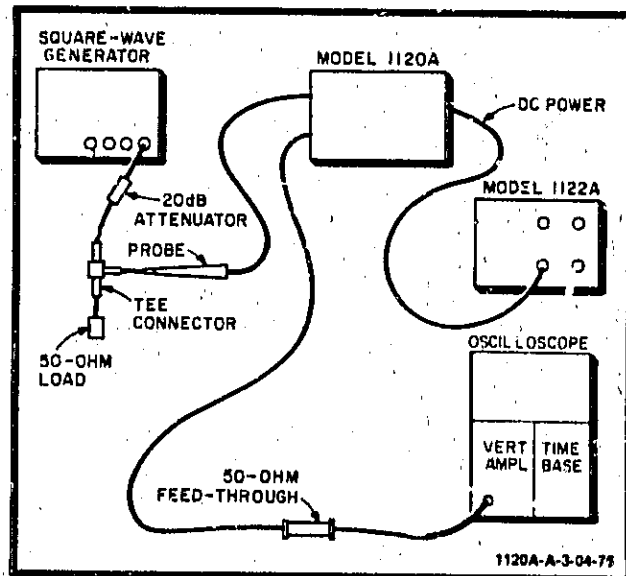

Figure 9. Low-frequency Gain Test Setup

Model 1120A

- c. Set the oscilloscope time-base unit for a sweep speed of 50 microseconds/division.
- d. Set the oscilloscope vertical amplifier for 0.1 volt/division vertical sensitivity, dc coupled.
- e. Adjust oscilloscope for a stable display.
- f. Observe preshoot and overshoot of the square-wave signals displayed on the oscilloscope CRT. If preshoot and overshoot appear excessive, proceed with step g. If preshoot and overshoot are not excessive, proceed with paragraph 26.
- g. Adjust the DC GAIN potentiometer (R17) on board assembly A1 so that the square-wave signals displayed on the CRT have the least amount of preshoot and overshoot.

26. Connect the equipment as shown in figure 10 for Offset Operation check.

- a. Set the Model 1120A controls as follows:

AC-DC switch DC
 OFFSET switch (+)
 OFFSET vernier fully ccw

- b. Center the sweep trace on the oscilloscope CRT.

- c. Rotate the OFFSET vernier of the Model 1120A in a clockwise direction. Limiting should be greater than +0.55 volt (approximately +0.6 volt).

- d. Set the OFFSET switch of the Model 1120A to (-). Limiting should be more negative than -0.55 volt (approximately -0.6 volt).

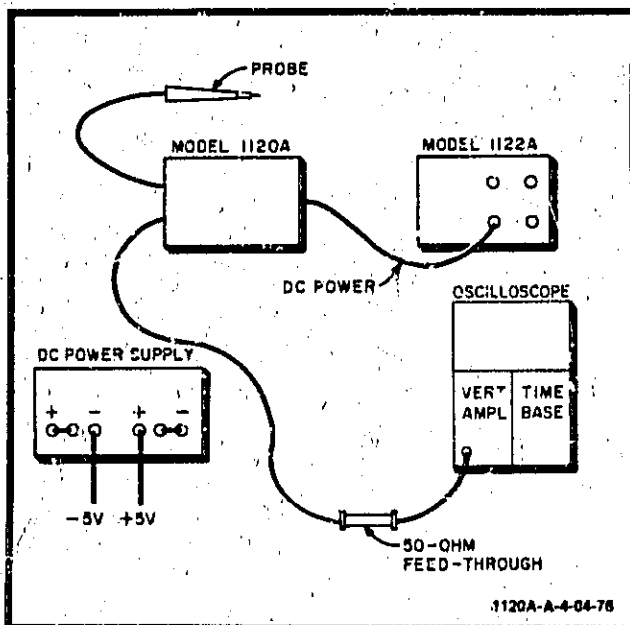

Figure 10. Offset Operation Test Setup

- e. With OFFSET switch of the Model 1120A in (-) position, apply +5.5 volts to the probe input. Rotate the OFFSET vernier. The oscilloscope trace should return to the center of the CRT.

NOTE

The potentiometer must be rotated several complete turns before the trace will begin to move (due to the dc input level).

- f. Set the OFFSET switch of the Model 1120A to the (+) position.

- g. Apply - 5.5 volts to the probe input.

- h. Rotating the OFFSET vernier should return the oscilloscope trace to the center of the CRT.

27. Connect the equipment as shown in figure 11 for the High-frequency check.

- a. Set the VHF oscillator for an output frequency of 500 MHz.

- b. Check the calibration of the two sampler channels to assure equal 500 MHz gain.

- c. Set the Model 1120A controls as follows:

AC-DC switch DC
 OFFSET switch OFF

- d. Measure the gain of the 1120A using the 4-GHz Sampler as a reference.

- e. The gain should be greater than .707 of the dc probe gain.

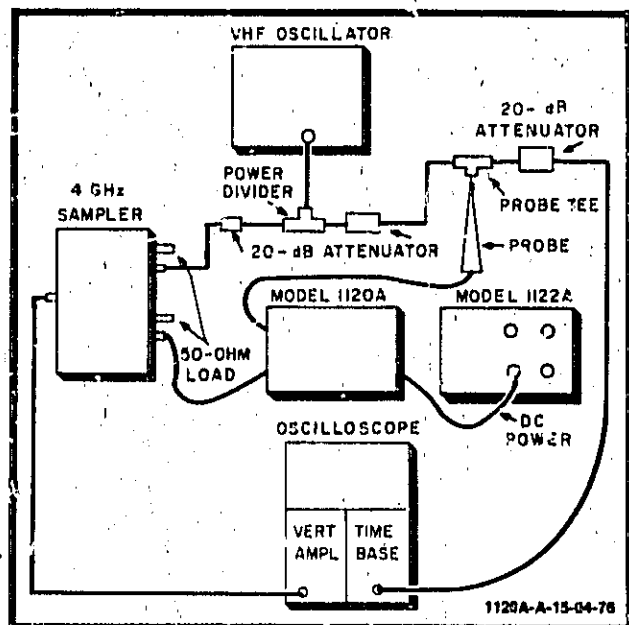

Figure 11. High-frequency Test Setup

28. Connect the equipment as shown in figure 12 for Pulse Rise Time and Gain check.

- a. Set the sampling time base to free run and trigger the pulse generator with the sync pulse output.
- b. Examine the pulse rise time (between 10% and 90%) on the 4-GHz sampler.
- c. Rise time shall be less than 0.75 nanosecond.
- d. Calibrate both channels of the sampler.
- e. Check the gain. Gain should be unity $\pm 5\%$ 45 nanoseconds after pulse rise.
- f. When measuring perturbation $\pm 10\%$, a 1-GHz sampler (HP Model 1810A) and 60 picoseconds pulse generator (HP Models 1105A/1108A) must be used.

29. The noise measurement of the Model 1120A (when observed on an oscilloscope) is dependent on:

- a. Bandwidth of the oscilloscope.
- b. Noise of the oscilloscope.
- c. Noise of the Model 1120A.
- d. Pick-up of noise at probe tip.

NOTE

Termination of the probe tip by a 50-ohm load will eliminate outside noise from the measurement. A screen room or any other low RFI environment can be used with the input open.

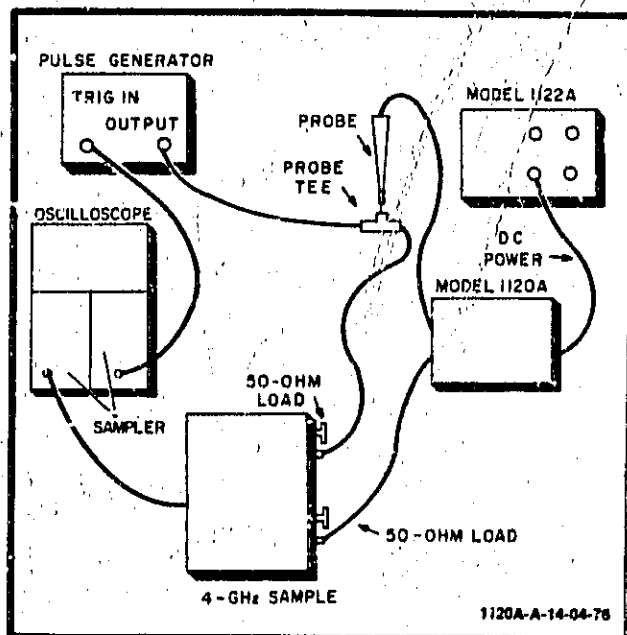

Figure 12. Rise Time Test Setup

30. Connect the equipment as shown in figure 13 for the Noise Measurement check.

- a. Set the Model 1120A controls as follows:

AC-DC switch	DC
OFFSET switch	OFF

- b. Set the oscilloscope time base unit to free run.

c. Reduce the amplitude of the input square-wave signal until no distinction can be made between the two levels of the square wave.

d. Reduce the attenuation by 10 on the square-wave generator.

e. Measure the signal amplitude. Divide this amplitude by 10 to obtain the tangential noise measurement. Compare measurement with the noise specifications listed in table 1.

31. Connect the equipment as shown in figure 14 for Input Capacitance check.

- a. Set frequency of RX Meter to 100 MHz.

b. Adjust DETECTOR TUNING and null RX Meter.

c. Apply power to the probe and connect the probe tip ground to the I/O terminal on the RX Meter. Connect the probe tip to the HI terminal.

- d. Capacitance should be less than 3 picofarads.

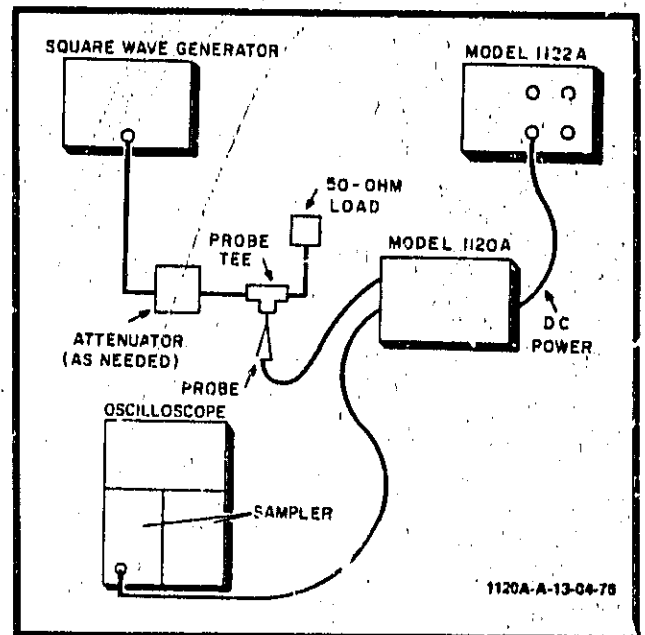

Figure 13. Noise Measurement Test Setup

PARTS

LIST

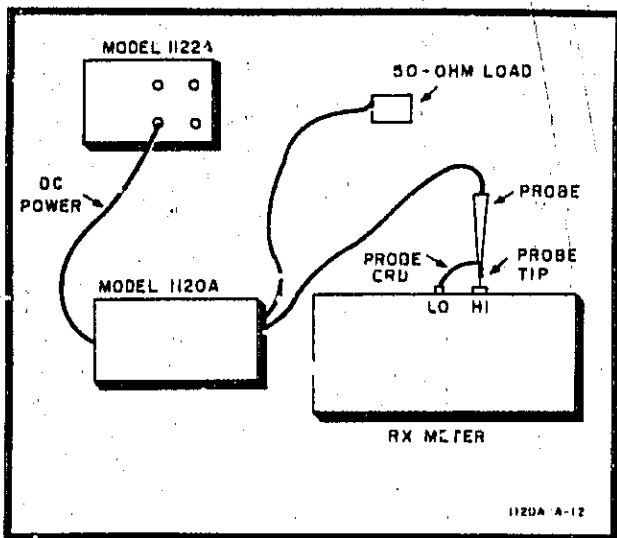

Figure 14. Input Capacitance Test Setup

32. When replacement of the active probe tip pin becomes necessary, proceed as follows:

a. Remove the damaged probe tip pin and discard.

Insert a new probe tip pin and tighten with the fingers.

c. Long nose pliers should be used for final seating.

CAUTION

Applying excessive pressure when seating the probe tip pin will result in damage to the probe-tip threads within the probe body.

33. The voltage dividers (Model 10241A and Model 10243A) are compensated at the factory and should require no adjustment in the field. If compensation is necessary, remove the voltage divider from the active probe. Adjust the slotted rate (as seen through the rear of the divider) for optimum pulse response.

34. TROUBLESHOOTING.

35. Trouble within the Model 1120A may be isolated by applying an ac signal to the active probe tip and operating the controller unit in the AC mode of operation. No signal or an improper output signal indicates a faulty probe. Since the active element within the probe is an integrated circuit, the unit must be replaced. If trouble is encountered in the DC-restore circuit, perform the adjustment checks to isolate the problem to the faulty stage. Normal troubleshooting procedure should be used to isolate the faulty component.

NOTE

The major cost of the probe assembly is in integrated circuit A2U1 and replacement in the field is difficult. Replacement of the complete probe assembly (A2, HP Part No. 01120-62101) is recommended rather than separate replacement of the integrated circuit.

36. OPTIONS.

OPTION 001. This option increases the length of the probe cable to approximately 6 feet. Electrical characteristics and specifications are identical to the standard Model 1120A. Part number differences for A2 are listed in table 4.

37. OLDER INSTRUMENTS.

38. This operating note applies directly to the standard Model 1120A having a serial prefix as shown on the first page of this operating note. Table 3 indicates changes required to adapt this operating note to an older instrument. Check table 3 for the proper instrument serial prefix and make the changes indicated.

Table 3. Operating Note Changes

Serial Prefix	Make Changes
946-, 1206A	3, 2, 1
1211A	3, 2
1304A	3

CHANGE 1

A1: Change to HP Part No. 01120-66501.
MP6: Change to HP Part No. 01120-00101.

CHANGE 2

Table 1,
MAXIMUM INPUT; change to ± 100 V.
Paragraph 23,
Under CAUTION, change +80 volts to ± 100 volts.

CHANGE 3

Page 12, table 4,
S1: Change to HP Part No. 3101-0199.

39. REPLACEABLE PARTS.

40. Table 4 lists the replaceable parts and identifies the Hewlett-Packard part number of each item.

41. To order a replaceable part from Hewlett-Packard, address the order to the nearest HP Sales/Service Office listed in the rear of this operating note. Include the instrument model number, the complete serial number, the reference designator of the part, and the HP Part number. If a part is not listed, provide a description of the part including function and location.

Table 4. Replaceable Parts

Ref Desig	HP Part No.	TO	Description
A1	01120-66502	1	A: board assembly, controller
A1C1	0180-0374	2	C: fxd Ta 10 uF 10% 20 wVdc
A1C2	0180-0374	2	C: fxd Ta 10 uF 10% 20 wVdc
A1C3	0160-3508	2	C: fxd cer 1 uF -20% 50 wVdc
A1C4	0160-3508	2	C: fxd cer 1 uF -20% 50 wVdc
A1C5	0130-2209	1	C: fxd mica 360 pF 5% 300 wVdc
A1C6	0160-0160	2	C: fxd my. 8200 pF 10% 200 wVdc
A1C7	0140-0198	1	C: fxd mica 200 pF 5% 300 wVdc
A1C8	0150-0093	1	C: fxd cer .01 uF -20% 100 wVdc
A1C9	0160-0160	2	C: fxd my. 8200 pF 10% 200 wVdc
A1CR1 thru A1CR10	1901-0040	10	CR: Si
A1L1	9100-1627	1	L: fxd 39 uH 5%
A1L2	9140-0210	1	L: fxd 100 uH 5%
A1L3	01817-62902	2	L: ferrite bead
A1L4	01817-62902	2	L: ferrite bead
A1Q1	1854-0221	1	Q: Si npn, dual
A1Q2	1853-0049	1	Q: Si pnp
A1Q3	1854-0071	3	Q: Si npn
A1Q4	1854-0071	1	Q: Si npn
A1Q5	1853-0020	1	Q: Si pnp
A1Q6	1854-0071	1	Q: Si npn
A1R1	0684-1061	1	R: fxd comp 10 megohms 10% 1/4 W
A1R2	0684-1531	2	R: fxd comp 15 kilohms 10% 1/4 W
A1R3	2100-1776	1	R: var ww 10 kilohms 10% 1/2 W
A1R4	2100-1774	1	R: var ww 2000 ohms 10% 1/2 W
A1R5	0757-0938	1	R: fxd metflm 3900 ohms 2% 1/8 W
A1R6	0757-0967	1	R: fxd metflm 62 kilohms 2% 1/8 W
A1R7	0757-0972	1	R: fxd metflm 100 kilohms 2% 1/8 W
A1R8	0757-0924	1	R: fxd metflm 1000 ohms 2% 1/8 W
A1R9	0757-0962	1	R: fxd metflm 39 kilohms 2% 1/8 W
A1R10	0684-4721	1	R: fxd comp 4700 ohms 10% 1/4 W
A1R11	0757-0954	1	R: fxd metflm 18 kilohms 2% 1/8 W
A1R12	0757-0951	1	R: fxd metflm 13 kilohms 2% 1/8 W
*A1R13	0684-0271	2	R: fxd comp 2.7 ohms 10% 1/4 W
A1R14	0684-0271	1	R: fxd comp 2.7 ohms 10% 1/4 W
A1R15	0684-1021	1	R: fxd comp 1000 ohms 10% 1/4 W
*A1R16	0757-0939	1	R: fxd metflm 4300 ohms 2% 1/8 W
A1R17	2100-1773	1	R: var ww 1000 ohms 10% 1/2 W
A1R18	0684-2221	1	R: fxd comp 2200 ohms 10% 1/4 W
A1R19	0757-0941	1	R: fxd metflm 5100 ohms 2% 1/8 W
A1R20	0757-0911	1	R: fxd metflm 300 ohms 2% 1/8 W
A1R21	0757-0928	2	R: fxd metflm 1500 ohms 2% 1/8 W
A1R22	0757-0932	1	R: fxd metflm 2200 ohms 2% 1/8 W
A1R23	0757-0907	2	R: fxd metflm 200 ohms 2% 1/8 W

(*) Factory selected part. May not be installed in the instrument.

Table 4. Replaceable Parts (Cont'd)

Ref Desig	HP Part No.	TO	Description
A1R24	0757-0907		R: fxd metflm 200 ohms 2% 1/8 W
A1R25	0757-0911		R: fxd metflm 300 ohms 2% 1/8 W
A1R26	0757-0928		R: fxd metflm 1500 ohms 2% 1/8 W
A1R27	0684-1531		R: fxd comp 15 kilohms 10% 1/4 W
A1R28	0757-0905	1	R: fxd metflm 160 ohms 2% 1/8 W
A1U1	1820-0058	1	U: integrated circuit
A1VR1	1902-3203	1	VR: breakdown 14.7 V 5% 400 mW
A2	01120-62101	1	A: assembly probe
A2	01120-62102	1	A: assembly probe (option 001)
A2C1	0180-2323	1	C: fxd Ta 0.1 uF +40 -20% 20 wVdc
A2C2	0180-2298	1	C: fxd Ta 6.8 uF +40 -20% 3 wVdc
A2E1	01120-26101	1	E: pin, probe
A2E2			Not assigned
A2MP1			Not assigned
A2MP2	01120-27701	1	MP: body, probe
A2MP3			Not assigned
A2MP4	01120-66101	1	Tip Assy: probe
A2U1	01120-61102	1	U: microcircuit assembly (replacement of complete probe assy A2 is recommended)
E1	01120-26101	4	E: pin, probe (spares)
E2	01123-61302	1	E: lead assembly, ground 2.5-in.
E3	10218A	1	E: adapter, probe BNC
E4	10229A	1	E: tip, hook
E5	10241A	1	E: 10:1 voltage divider
E6	10242A	1	E: bandwidth limiter
E7	10243A	1	E: 100:1 voltage divider
E8	5060-0549	1	E: spanner tip assembly
MP1	01120-00201	1	MP: panel, front
MP2	01120-25202	1	MP: housing, controller assembly
MP3	01120-67401	1	MP: knob assembly
MP4	01120-64701	1	MP: mounting bracket
MP5	4040-0457	1	MP: holder, probe
MP6	01120-00102	1	MP: chassis
R1	2100-2916	1	R: var comp 5000 ohms 10% 1/2 W
S1	3101-1593	1	S: slide, DPDT, AC-DC
S2	3101-1266	1	S: slide, 3 pos, OFFSET
W2	01120-61602	1	W: cable assembly, output
W3	01120-61603	1	W: cable assembly, power

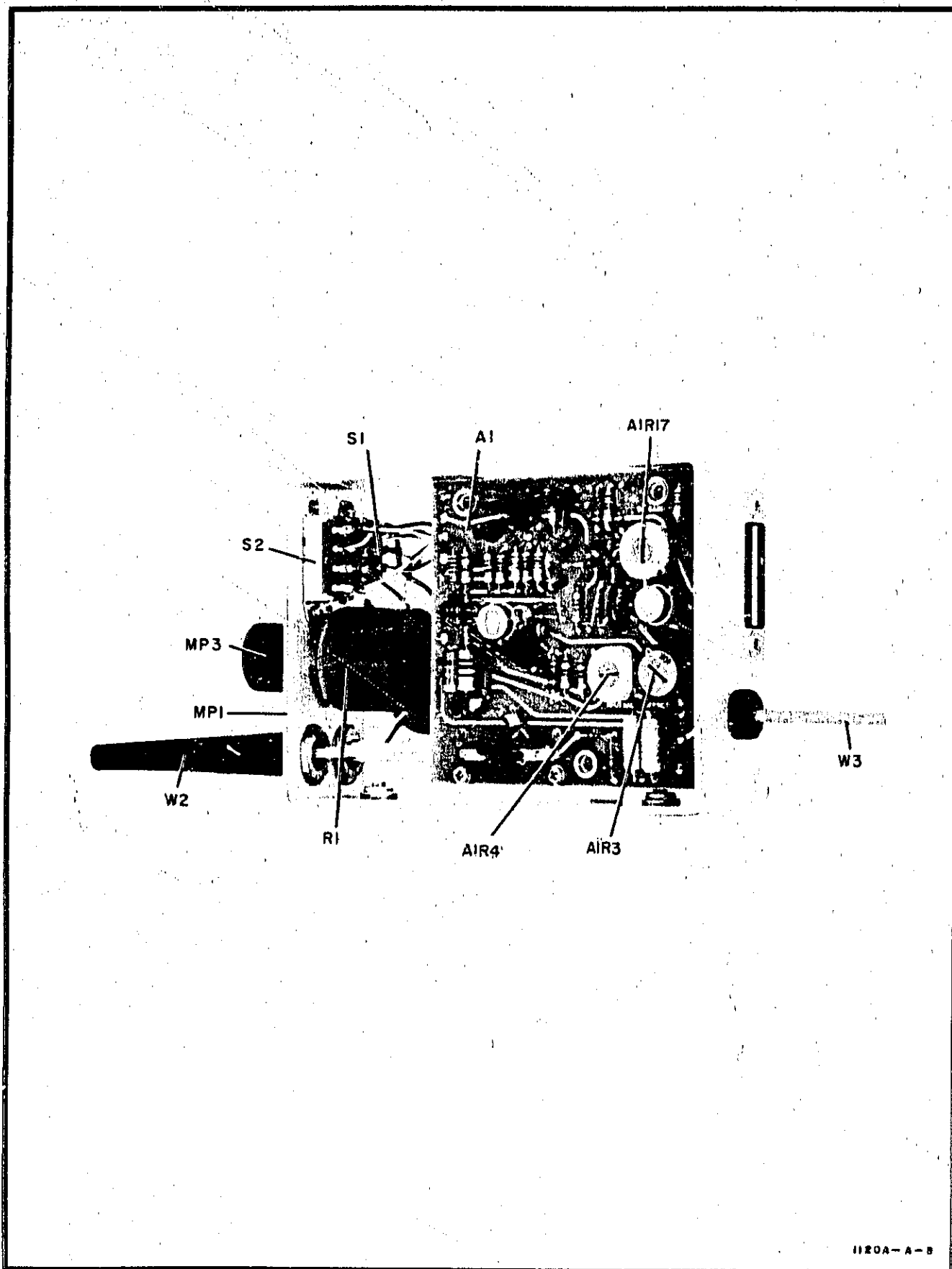

1120A-A-8

Figure 15. Chassis Component Identification

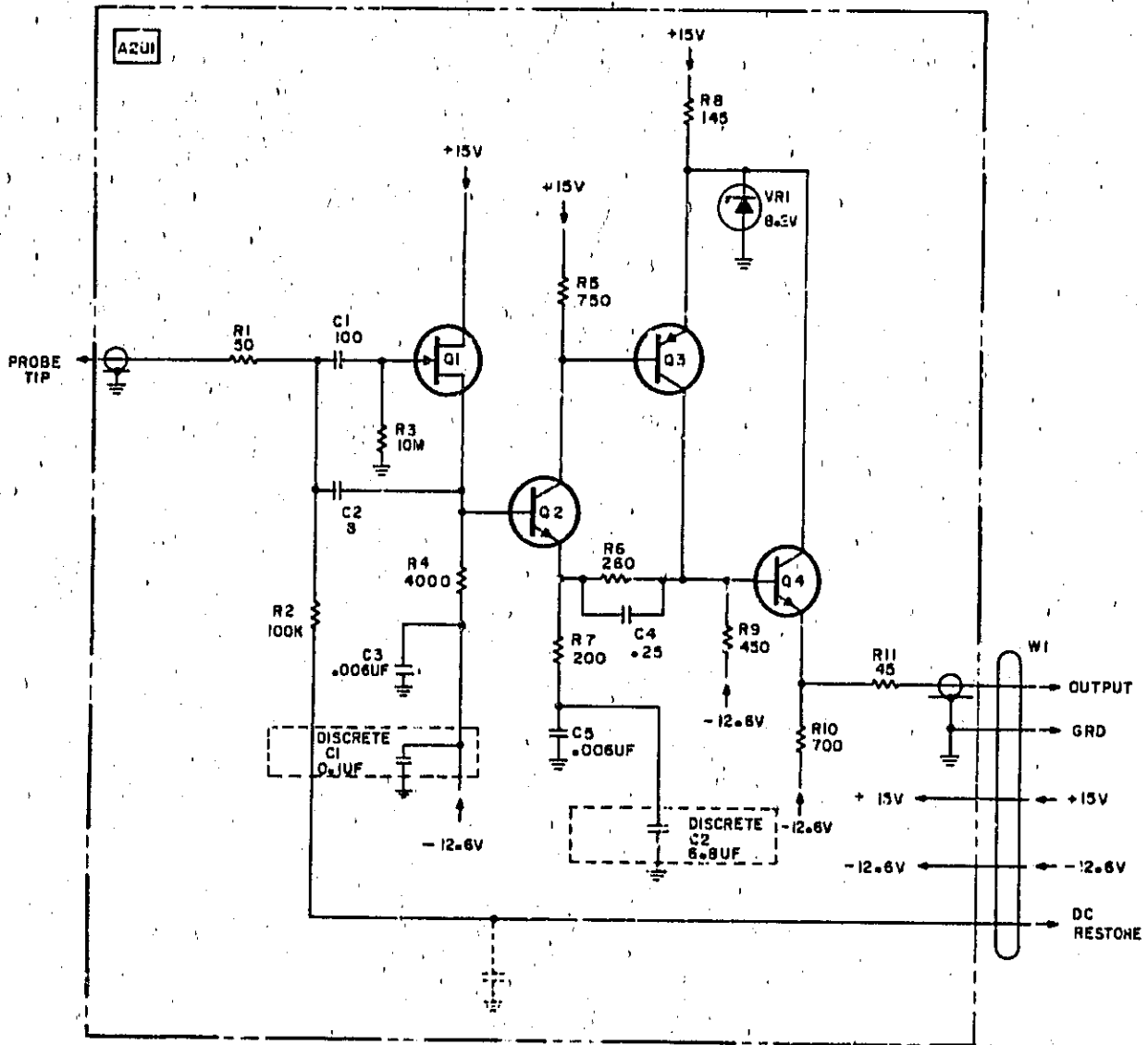

NOTE: A2U1 MICROCIRCUIT NOT REPARABLE. REPLACE AS A UNIT.

MODEL 1120A HYBRID PROBE

REFERENCE DESIGNATIONS

A2U1	DISCRETE
C1-5	C1,C2
Q1-4	
R1-11	
VRI	

Figure 16. Voltage Probe Hybrid Schematic

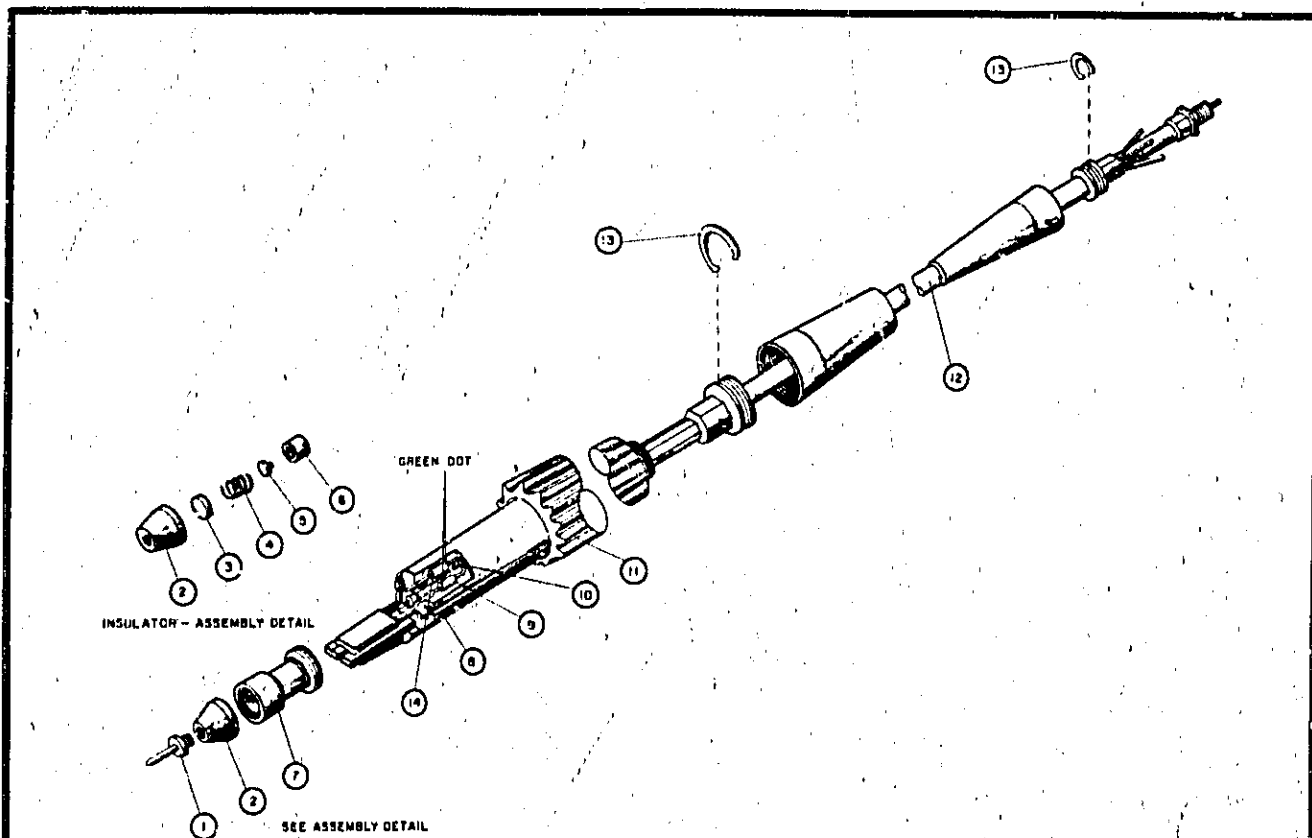

ITEM	DESCRIPTION	HP PART NO.
1	Pin, probe	01120-26101
2	Insulator, probe pin	NSR
3	Contact, front	NSR
4	Spring	NSR
5	Contact, rear	NSR
6	Bushing, insulator	NSR
7	Sleeve, probe	NSR
8	Microcircuit, heat sink assy	NSR
9	Capacitor, fixed	0180-2298
10	Screw, fil. hd 0-80 x 062	0516-0034
11	Body, probe	01120-27701
12	Cable assembly, probe	01120-61601
13	Retaining ring, crescent	0510-0091
14	Capacitor, fixed	0180-2323

NOTE

Items 2 thru 8 are not separately replaceable. Items 2 thru 7 are collectively replaceable as A2MP4. Item 8 is p/o A2U1.

Figure 17. Probe Assembly A2 Breakdown

Model 1120A

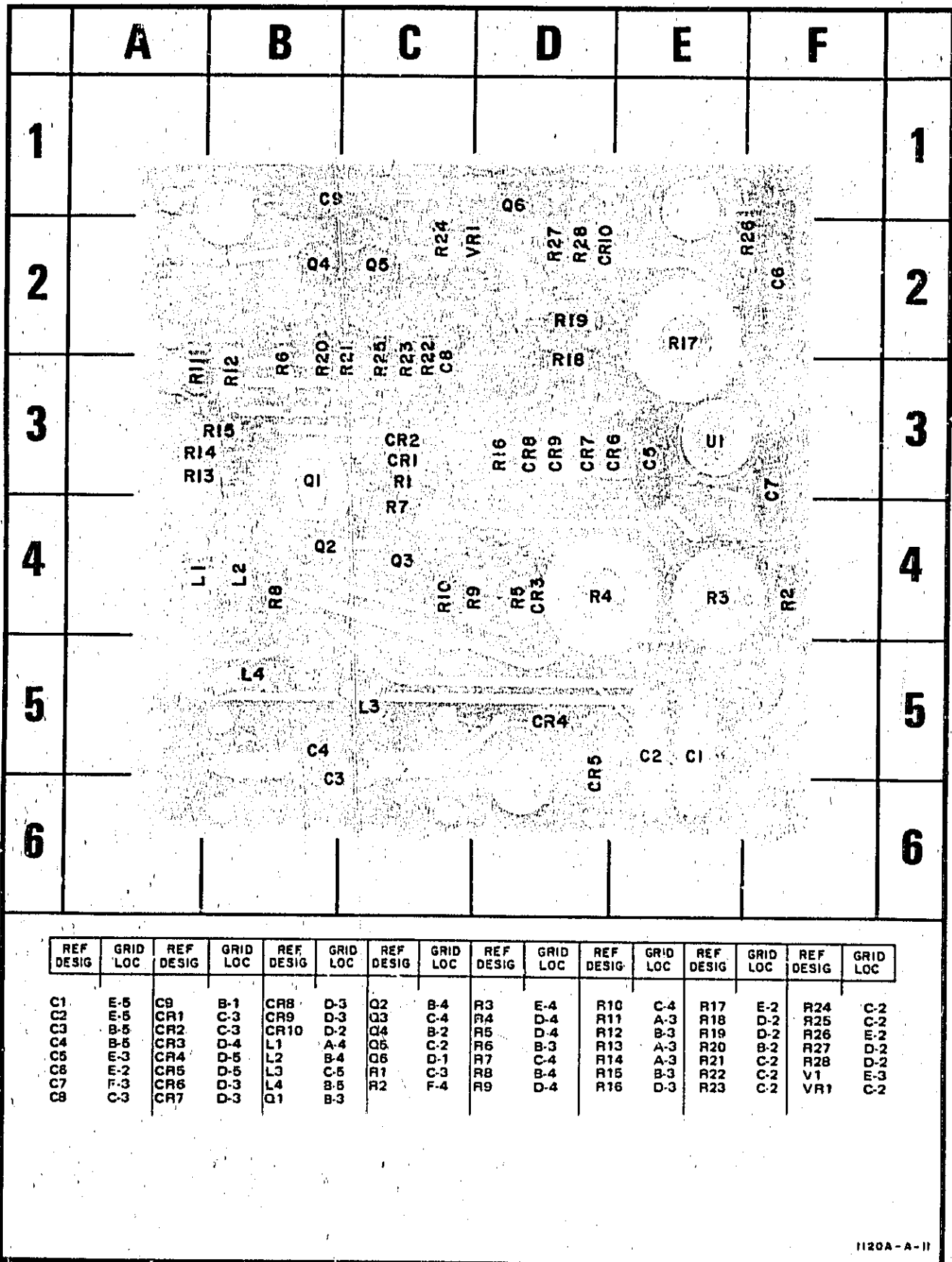

1120A-A-11

Figure 18. Board Assembly A1 Component Identification

Figure 19. DC-restore Circuit Schematic

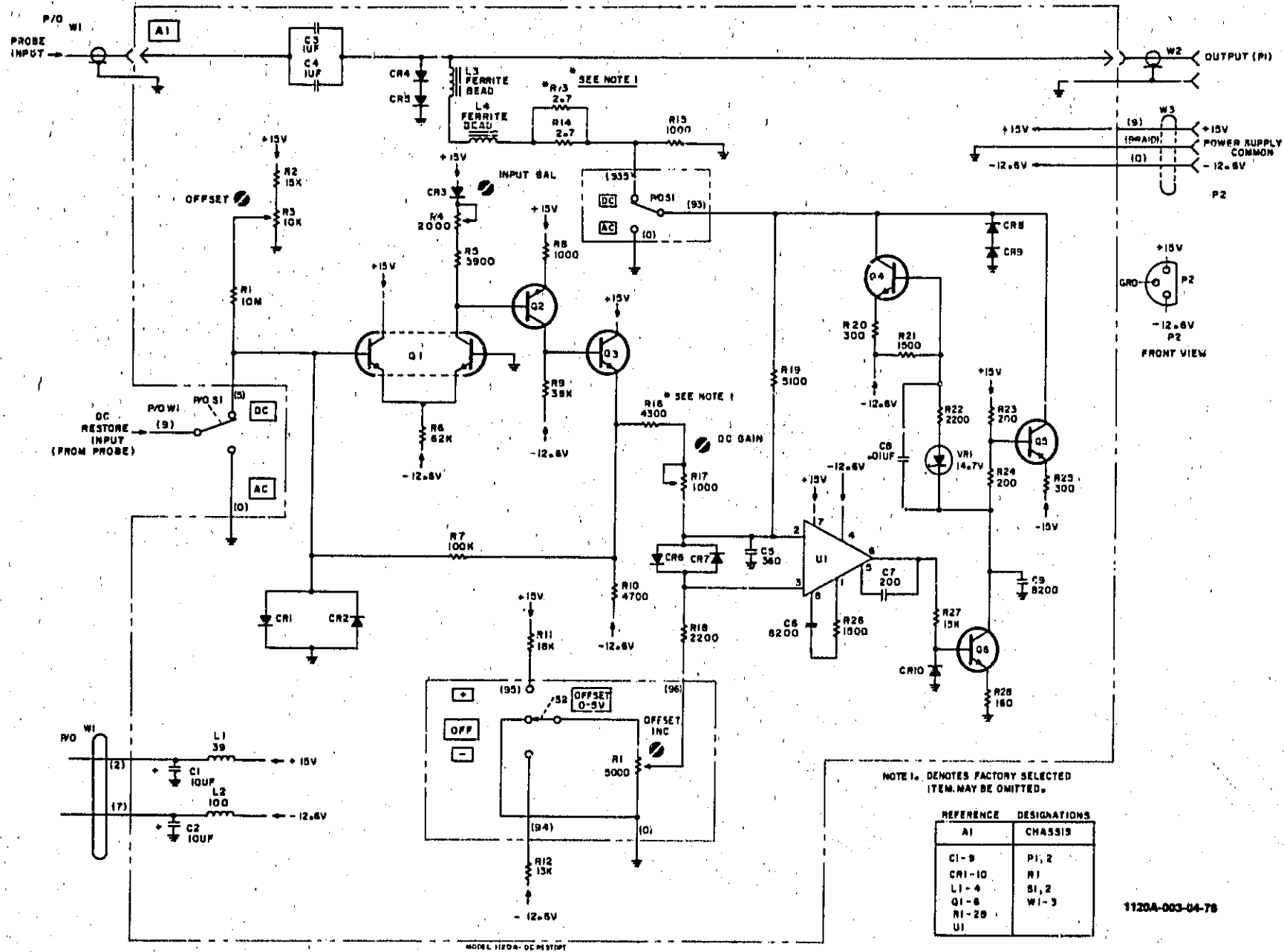

1120A-003-04-78

Model 1120A

SAFETY

This product has been designed and tested according to International Safety Requirements. To ensure safe operation and to keep the product safe, the information, cautions, and warnings in this manual must be heeded. Refer to Section I and the Safety Summary for general safety considerations applicable to this product.

CERTIFICATION

Hewlett-Packard Company certifies that this product met its published specifications at the time of shipment from the factory. Hewlett-Packard further certifies that its calibration measurements are traceable to the United States National Bureau of Standards, to the extent allowed by the Bureau's calibration facility, and to the calibration facilities of other International Standards Organization members.

WARRANTY

This Hewlett-Packard product is warranted against defects in material and workmanship for a period of one year from date of shipment. During the warranty period, Hewlett-Packard Company will, at its option, either repair or replace products which prove to be defective.

For warranty service or repair, this product must be returned to a service facility designated by HP. However, warranty service for products installed by HP and certain other products designated by HP will be performed at Buyer's facility at no charge within the HP service travel area. Outside HP service travel areas, warranty service will be performed at Buyer's facility only upon HP's prior agreement and Buyer shall pay HP's round trip travel expenses.

For products returned to HP for warranty service, Buyer shall prepay shipping charges to HP and HP shall pay shipping charges to return the product to Buyer. However, Buyer shall pay all shipping charges, duties, and taxes for products returned to HP from another country.

LIMITATION OF WARRANTY

The foregoing warranty shall not apply to defects resulting from improper or inadequate maintenance by Buyer, Buyer-supplied software or interfacing, unauthorized modification or misuse, operation outside of the environmental specifications for the product, or improper site preparation or maintenance.

NO OTHER WARRANTY IS EXPRESSED OR IMPLIED. HP SPECIFICALLY DISCLAIMS THE IMPLIED WARRANTIES OF MERCHANTABILITY AND FITNESS FOR A PARTICULAR PURPOSE.

EXCLUSIVE REMEDIES

THE REMEDIES PROVIDED HEREIN ARE BUYER'S SOLE AND EXCLUSIVE REMEDIES. HP SHALL NOT BE LIABLE FOR ANY DIRECT, INDIRECT, SPECIAL, INCIDENTAL, OR CONSEQUENTIAL DAMAGES, WHETHER BASED ON CONTRACT, TORT, OR ANY OTHER LEGAL THEORY.

ASSISTANCE

Product maintenance agreements and other customer assistance agreements are available for Hewlett-Packard products.

For any assistance, contact your nearest Hewlett-Packard Sales and Service Office. Addresses are provided at the back of this manual.

07

MANUAL CHANGES

MANUAL CHANGES

MANUAL IDENTIFICATION

Model Number: 1120A
 Date Printed: FEBRUARY 1983
 Part Number: 01120-90903

This supplement contains important information for correcting manual errors and for adapting the manual to instruments containing improvements made after the printing of the manual.

To use this supplement:

Make all ERRATA corrections.

Make all appropriate serial number related changes indicated in the tables below.

Serial Prefix or Number	Make Manual Changes	Serial Prefix or Number	Make Manual Changes
2344A	OP NOTE APPLIES		

† NEW ITEM(S)

† ERRATA:

- Page 12, Table 4, Replaceable parts.
- Change: A2 HP Part No. to 01120-62103
- Change: A2 (option 001) HP Part No. to 01120-62104
- Change: A2MP4 HP Part No. to 01120-68102

NOTE

Manual change supplements are revised as often as necessary to keep manuals as current and accurate as possible. Hewlett-Packard recommends that you periodically request the latest edition of this supplement. Free copies are available from all HP offices. When requesting copies quote the manual identification information from your supplement, or the model number and print date from the title page of the manual.

